

**Water Fuel Cell**

**Hydrogen Fracturing Process**

*on*

**How To Use Voltage To Stimulate The Water Molecule To Produce  
Atomic Rocket-Fuel On Demand**

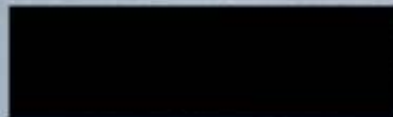

**Inventor:**  
**Stanley A. Meyer**  
**3792 Broadway**  
**Grove City, Ohio 43123**  
**1-614-871-4173**

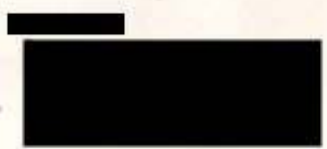

### Water Fuel Cell

Water Fuel Cell

### Hydrogen Fracturing Process

Hydrogen Fracturing Process

#### To Whom It May Concern,

Over the Years man has used water in many ways to make his life on Earth more productive. Why not, now, use **water as fuel** to power our cars, heat our homes, fly our planes or propel spaceships beyond our galaxy? Biblical prophesy foretells this event.

After all, the energy contained in an gallon of water exceeds 2.5 million barrels of oil when equated in terms of atomic energy. Water, of course, is free and abundant.

The Hydrogen Fracturing Process dissociates the water molecule by way of voltage deflection, ionizes the combustible gases by light exposure and, then, prevents the formation of the water molecule during thermal gas ignition....releasing thermal explosive energy beyond "normal" gas burning levels under control-state.

The atomic process is environmentally safe and requires "No" neutron interaction to trigger the energy-process.

The Hydrogen Fracturing Process is systematically activated and performed in the following way:



220 Watt Power/Electric Engine  
Data Reference: WFC Tech-Brief

Method: Using Voltage to stimulate the water molecule to produce Atomic  
Rocket-Fuel on Demand.

Operational Parameters

## Water Fuel Cell

### Hydrogen Fracturing Process

on

### How To Use Voltage To Stimulate The Water Molecule To Produce Atomic Rocket-Fuel On Demand

Copyright © 1981 By Stanley A. Meyer



**Inventor:**  
**Stanley A. Meyer**  
 3792 Broadway  
 Grove City, Ohio 43123  
 1-614-871-4173

Copyright © 1983 in U.S.A. By Stanley A. Meyer  
 © under UCC 1987 By Stanley A. Meyer  
 U.S. and Foreign Patents Pending

**Method:** Using Voltage to stimulate the water molecule to produce Atomic Rocket-Fuel on Demand.

**Operational Parameters**

**BLOCKING DIODE (b)**

Blocking Diode (b) prevents electrical "shorting" to secondary coil (A) during pulse off time. Once the pulse "only" conducts electrical energy in the direction of the schematic shown.

**EXCITATOR**

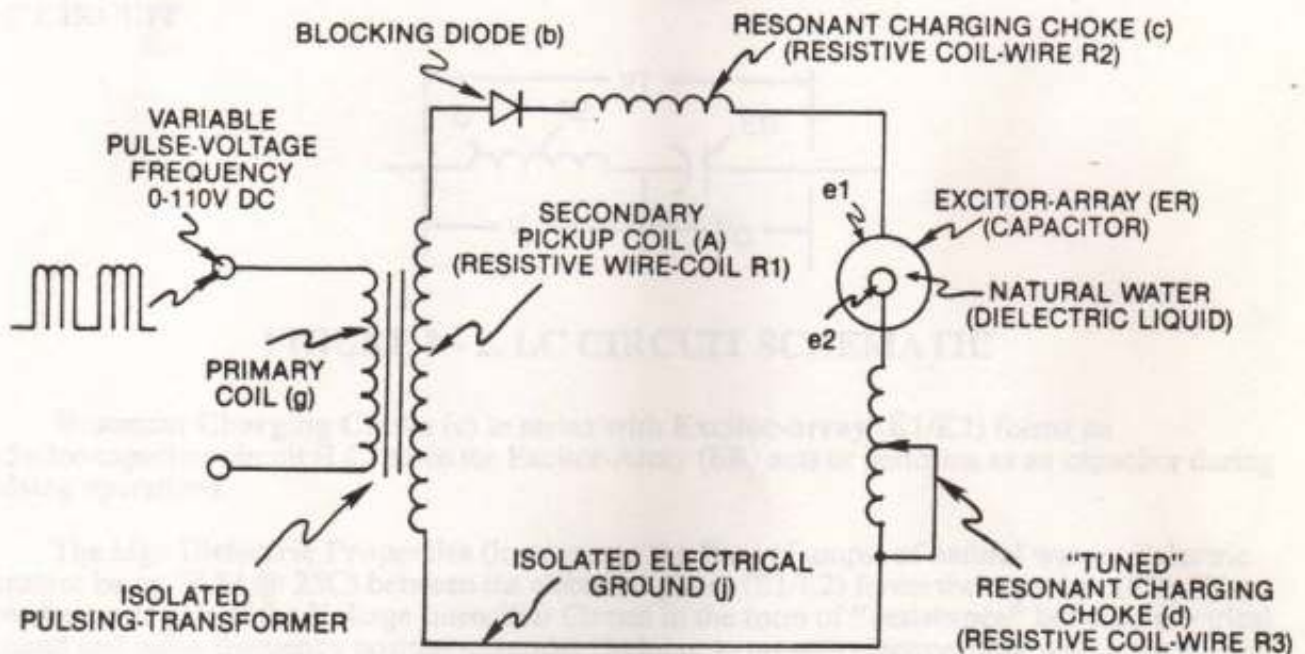

Copyright © 1981 By Stanley A. Meyer

**Figure 1 - 1. Voltage Intensifier Circuit (AA)**

## CIRCUIT COMPONENT INTERACTION

### PULSING TRANSFORMER (G)

The pulsing transformer (G) steps up voltage amplitude or voltage potential during pulsing operations. The primary coil is electrically isolated (no electrical connection between primary and secondary coil) to form **Voltage Intensifier Circuit (AA)**. Voltage amplitude or voltage potential is increase when secondary coil is wrapped with more turns of wire. Isolated electrical ground (J) prevents electron flow from input circuit ground.

### BLOCKING DIODE (B)

Blocking Diode (B) prevents electrical "shorting" to secondary coil (A) during pulse-off time since the diode "only" conducts electrical energy in the direction of the schematic arrow.

### LC CIRCUIT

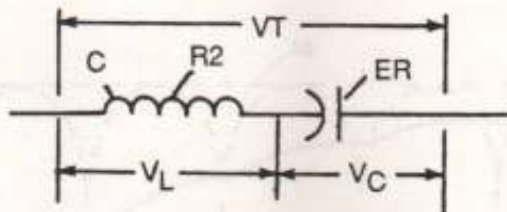

FIGURE 1 - 2. LC CIRCUIT SCHEMATIC

**Resonant Charging Choke (c)** in series with **Excitor-array (E1/E2)** forms an inductor-capacitor circuit (LC) since the Excitor-Array (ER) acts or performs as an capacitor during pulsing operations.

The high **Dielectric Properties** (insulator to the flow of amps) of natural water (dielectric constant being 78.54 @ 25C) between the electrical plates (E1/E2) forms the capacitor (ER). Water now becomes part of the Voltage Intensifier Circuit in the form of "resistance" between electrical ground and pulse-frequency positive-potential...helping to prevent electron flow within the pulsing circuit (AA) of Figure 1-1).

The **Inductor (C)** takes-on or becomes an **Modulator Inductor** which steps up an oscillation of an given charging frequency with the effective capacitance of an pulse-forming network in order to charge the voltage zones (E1/E2) to an higher potential beyond applied voltage input.

The Inductance (C) and Capacitance (ER) properties of the LC circuit is therefore "tuned" to resonance at a certain frequency. The **Resonant Frequency** can be raised or lowered by changing the inductance and/or the capacitance values. The established resonant frequency is, of course, independent of voltage amplitude, as illustrated in Figure 9BB as to Figure 16A.

The value of the Inductor (C), the value of the capacitor (ER), and the pulse-frequency of the voltage being applied across the LC circuit determines the impedance of the LC circuit.

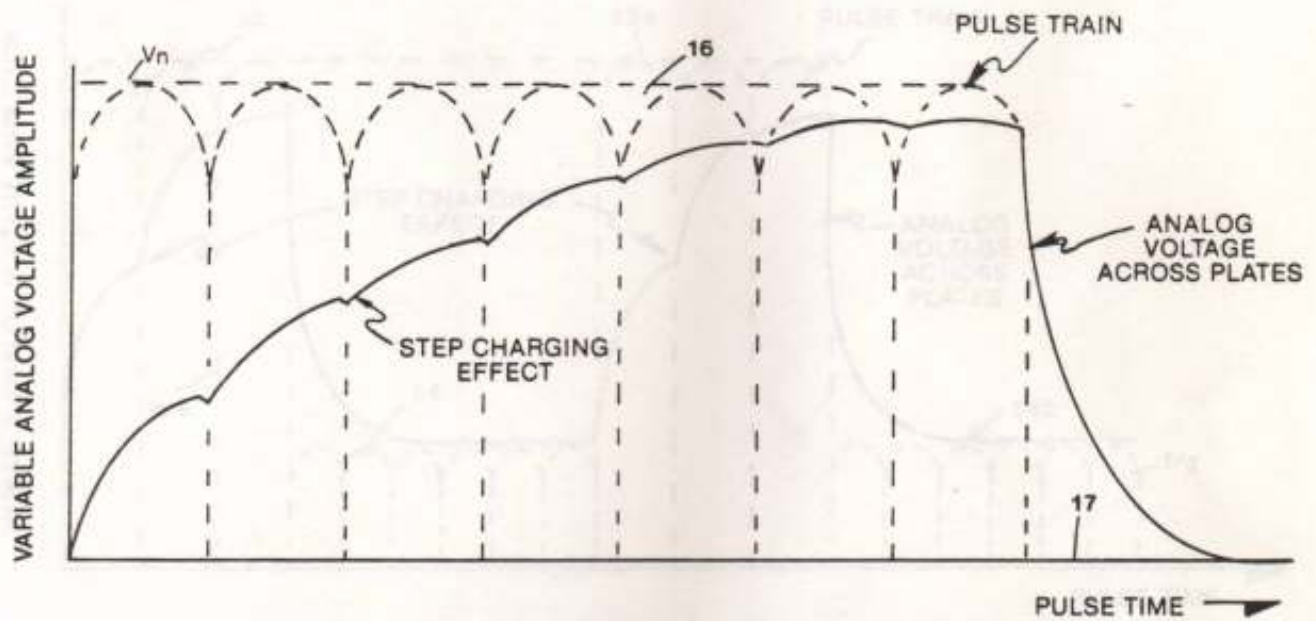
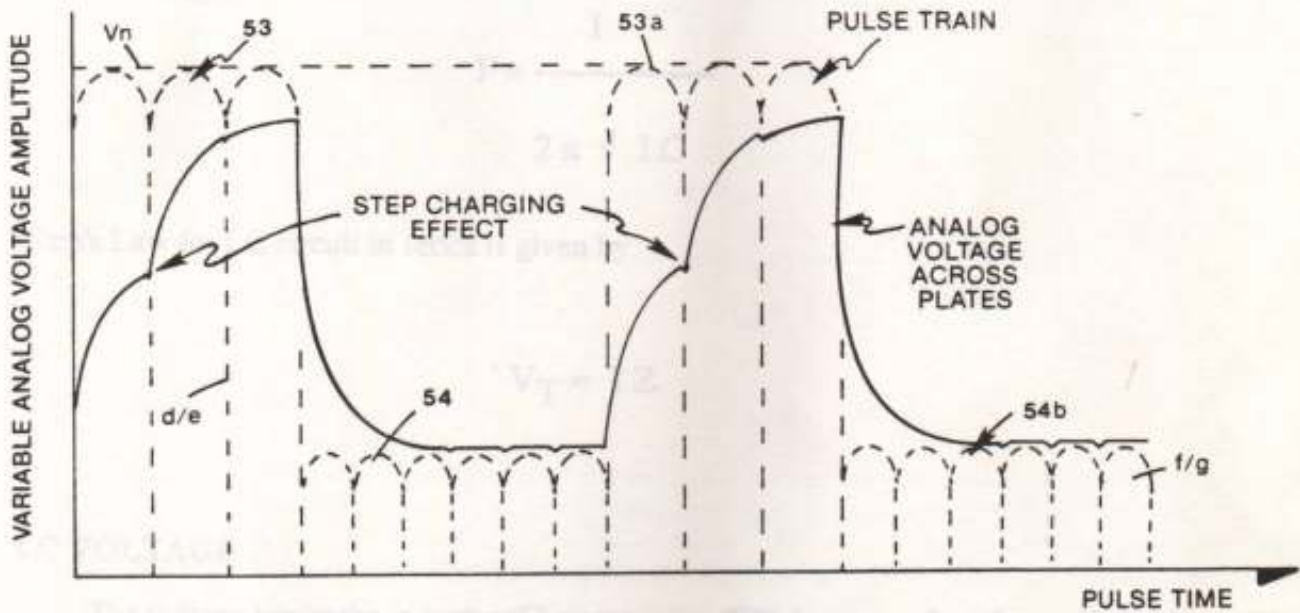

FIG. 9BB: APPLIED VOLTAGE TO PLATES

COPYRIGHT © 1981 BY STANLEY A. MEYER



**FIG. 16A: APPLIED VOLTAGE TO RESONANT CAVITY**

COPYRIGHT © 1982 BY STANLEY A. MEYER

The impedance of an inductor and a capacitor in series,  $Z_{\text{series}}$  is given by

$$Z_{\text{series}} = (X_C - X_L)$$

Where

$$X_C = \frac{1}{2\pi FC} \qquad X_L = 2\pi FL$$

The Resonant Frequency (F) of an LC circuit in series is given by

$$F = \frac{1}{2\pi \sqrt{LC}}$$

Ohm's Law for LC circuit in series is given by

$$V_T = IZ$$

## LC VOLTAGE

The voltage across the inductor (C) or capacitor (ER) is greater than the applied voltage (H). At frequency close to resonance, the voltage across the individual components is higher than the applied volatge (H), and, at resonant frequency, the voltage  $V_t$  across both the inductor and the capacitor are theoretically infinite, However, physical constraints of components and circuit interaction prevents the voltage from reaching infinity.

The voltage ( $V_L$ ) across the inductor (C) is given by the equation

$$V_L = \frac{V_T X_L}{(X_L - X_C)}$$



The voltage ( $V_C$ ) across the capacitor is given by

$$V_C = \frac{V_T X_C}{(X_L - X_C)}$$

During resonant interaction, the incoming unipolar pulse-train (H) of Figure (1-1) as to Figure (9B) produces an step-charging voltage-effect across Excitor-Array (ER), as illustrated in Figure (9BB) and Figure (16A). Voltage intensity increases from zero "ground-state" to an high positive voltage potential in an progressive function. Once the voltage-pulse is terminated or switch-off, voltage potential returns to "ground-state" or near ground-state to start the voltage deflection process over again.

Voltage intensity or level across Excitor-Array (ER) can exceed 20,000 volts due to circuit (AA) interaction and is directly related to pulse-train (H) variable amplitude input.

### RLC CIRCUIT

Inductor (C) is made of or composed of resistive wire (R2) to further restrict D.C. current flow beyond inductance reaction ( $X_L$ ), and, is given by

$$Z = \sqrt{R_1^2 + (X_L - X_C)^2}$$

### Dual-inline RLC NETWORK

Variable inductor-coil (D), similar to inductor (C) connected to opposite polarity voltage zone (E2) further inhibits electron movement or deflection within the Voltage Intensifier Circuit. Moveable wiper arm fine "tunes" "Resonant Action" during pulsing operations. Inductor (D) in relationship to inductor (C) electrically balances the opposite voltage electrical potential across voltage zones (E1/E2).

### VIC RESISTANCE

Since pickup coil (A) is also composed of or made of resistive wire-coil (R1), then, total circuit resistance is given by

$$Z = R_1 + Z_2 + Z_3 + R_E$$

Where,  $R_E$  is the dielectric constant of natural water

Copyright © 1984 by Stanley A. Meyer

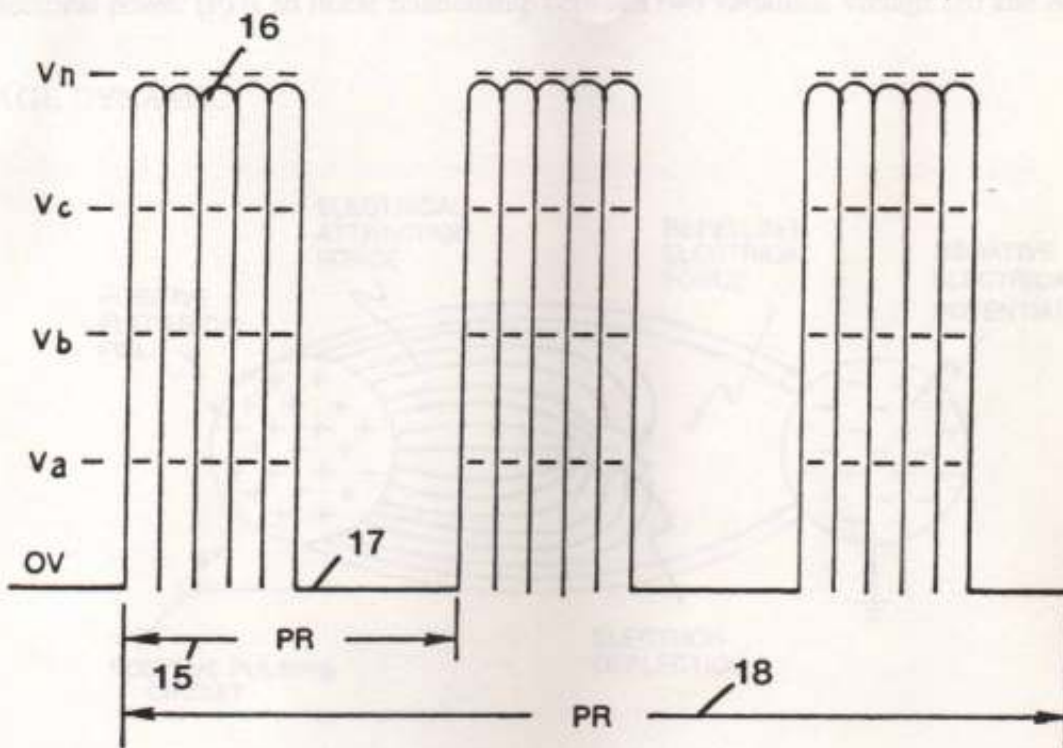

**FIG. 9B: VARIABLE AMPLITUDE UNIPOLAR PULSE VOLTAGE FREQUENCY SUPER IMPOSED ONTO AN 50% DUTY-CYCLE PULSE-TRAIN DYNAMICALLY CONTROLS THE HYDROGEN GAS-RATE WHILE RESTRICTING AMP FLOW.**

Copyright © 1981 by Stanley A. Meyer

$$E = I R$$

Where

$$P = E I$$

Whereby

Electrical power (P) is an linear relationship between two variables, voltage (E) and AMPS (I).

### VOLTAGE DYNAMIC

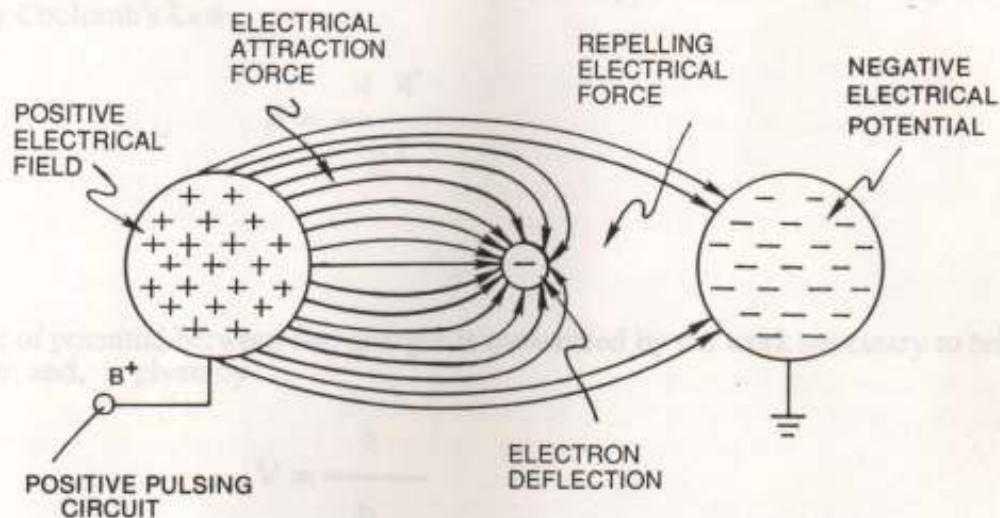

Figure 1-3. Voltage Potential Difference

### POTENTIAL ENERGY

Voltage is "electrical pressure" or "electrical force" within an electrical circuit and is known as "voltage potential". The higher the voltage potential, the greater "electrical attraction force" or "electrical repelling force" is applied to the electrical circuit. Voltage potential is an "unaltered" or "unchanged" energy-state when "electron movement" or "electron deflection" is prevented or restricted within the electrical circuit.

### VOLTAGE PERFORMS WORK

Unlike voltage charges within an electrical circuit set up an "electrical attraction force"; whereas, like electrical charges within the same electrical circuit encourages an "repelling action". In both cases, electrical charge deflection or movement is directly related to applied voltage. These electrical "forces" are known as "voltage fields" and can exhibit either a positive or negative electrical charge.

Likewise, Ions or Particles within the electrical circuit having unlike electrical charges are attracted to each other. Ions or particles mass having the same or like electrical charges will move away from one another, as illustrated in Figure 1-3.

Furthermore, electrical charged ions or particles can move toward stationary voltage fields of opposite polarity, and, is given by Newton's second Law

$$\vec{A} = \frac{\vec{F}}{M}$$

Where

The acceleration ( $\vec{A}$ ) of an particle mass (M) acted on by a Net Force ( $\vec{F}$ ).

Whereby

Net Force ( $\vec{F}$ ) is the "electrical attraction force" between opposite electrically charged entities, and, is given by Coulomb's Law

Figure 1-4. Charges of an Atom

$$F = \frac{q \cdot q'}{R^2}$$

Whereas

Difference of potential between two charges is measured by the work necessary to bring the charges together, and, is given by

$$V = \frac{q}{eR}$$

The potential at a point due to a charge (q) at a distance (R) in a medium whose dielectric constant is (e).

## ATOMIC INTERACTION TO VOLTAGE STIMULATION

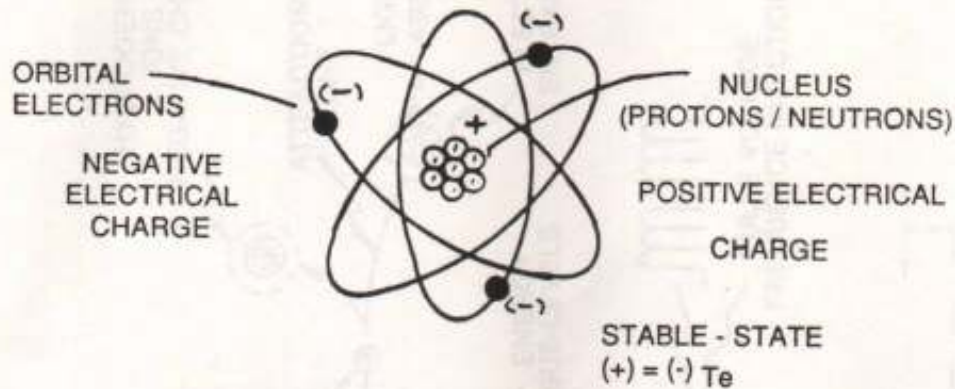

**Figure 1-4. Electrical Charges of an Atom**

Atomic structure of an atom exhibits two types of electrical charged mass-entities, orbital electrons having negative electrical charges (-) and an Nucleus (at least one proton) having a positive electrical charge (+). The positive electrical charge of the Nucleus equals the sum total of all negative electrical charged electrons when the Atom is in "stable-state".

In stable-state or normal-state, the number of electrons equals the number of protons to give the atom "NO" net electrical charge.

Whenever one or more electrons are "dislodged" from the atom, the atom takes-on a net positive electrical charge and is called a **positive ion**. If an electron combines with a stable or normal atom, the atom has a net negative charge and is called a **negative ion**.

Voltage potential within an electrical circuit can cause one or more electrons to be **dislodged** from the atom due to opposite electrical polarity attraction between unlike charged entities, as shown in Figure 20F (see Figure 1-3 again) as to Newton's and Coulomb's Laws of **electrical-force**.

Newton's and Coulomb's Laws of electrical-force is used to combine or join atoms together by way of **Covalent Bonding** (sharing electrons between atoms) to form a molecule of gas, liquid, or solid.

The liquid molecule of water is formed when the two Hydrogen atoms takes-on a net "**positive electrical charge**", which is, equal to the net "**negative electrical charge**" of the Oxygen atom. The opposite electrical force ( $qq'$ ) between the Hydrogen and Oxygen atoms keeps the water molecule intact when the sharing of electrons move from one atom structure to another. The strength of the **electrical attraction force** ( $qq'$ ) between the water molecule atoms is determined by the electrical-size of the hydrogen atoms and the displacement of the negative charged electrons during covalent sharing.

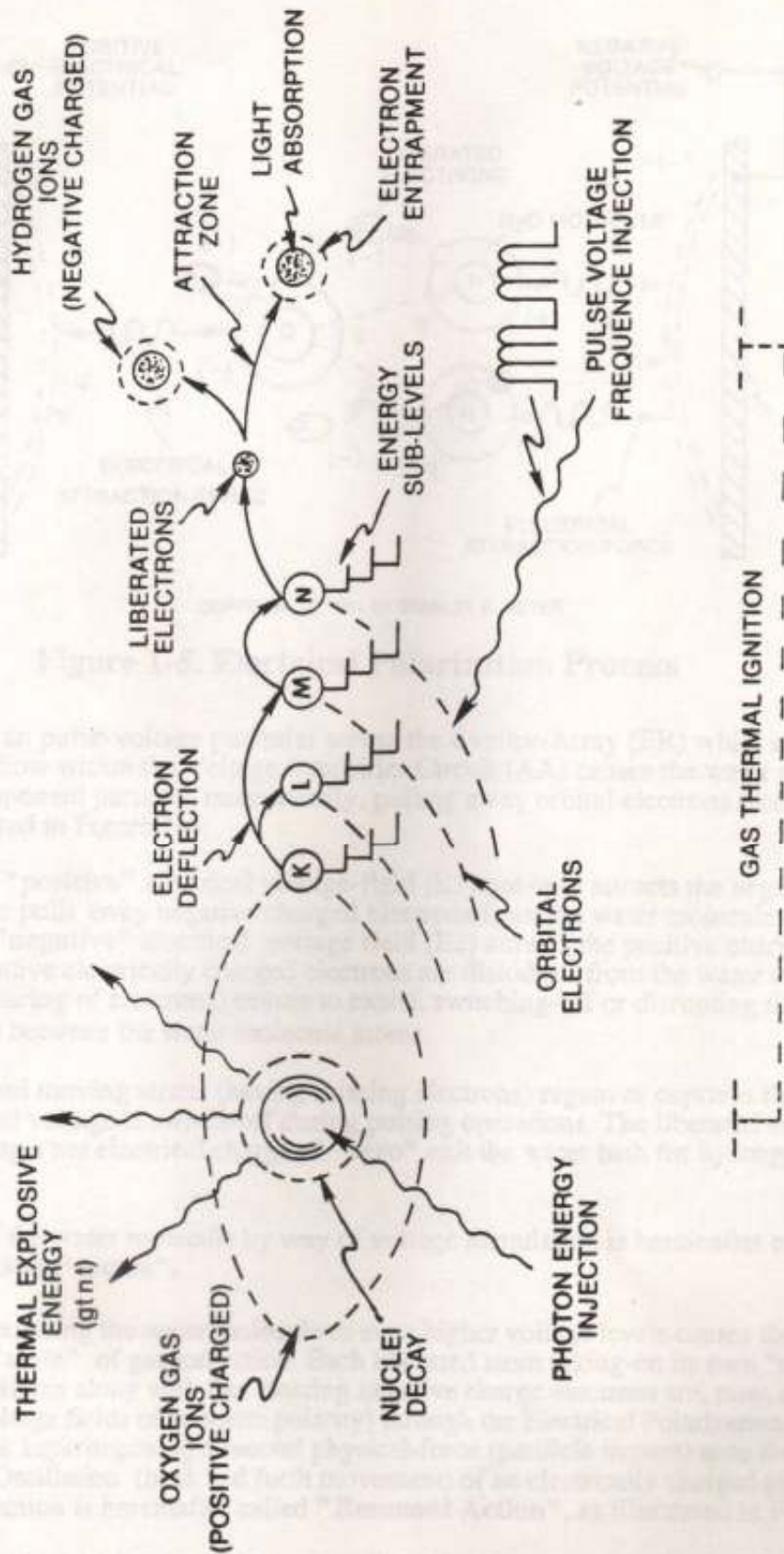
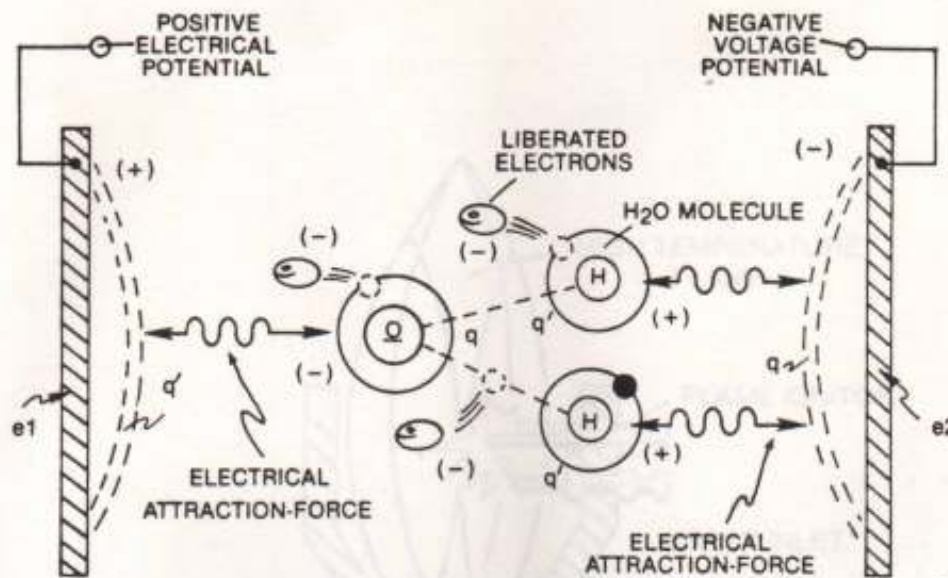

FIG. 20F: HYDROGEN FRACTURING PROCESS

COPYRIGHT © 1983 BY STANLEY A. MEYER

## VOLTAGE DISSOCIATION OF THE WATER MOLECULE



COPYRIGHT © 1981 BY STANLEY A. MEYER

Figure 1-5. Electrical Polarization Process

Placement of an pulse-voltage potential across the Excitor-Array (ER) while inhibiting or preventing electron flow within the Voltage Intensifier Circuit (AA) causes the water molecule to separate into its component parts by, momentarily, pulling away orbital electrons from the water molecule, as illustrated in Figure 1-5.

The stationary "positive" electrical voltage-field (E1) not only attracts the negative charged oxygen atom but also pulls away negative charged electrons from the water molecule. At the same time, the stationary "negative" electrical voltage field (E2) attracts the positive charged hydrogen atoms. Once the negative electrically charged electrons are dislodged from the water molecule, covalent bonding (sharing of electrons) ceases to exist, switching-off or disrupting the electrical attraction force ( $qq'$ ) between the water molecule atoms.

The liberated and moving atoms (having missing electrons) regain or captures the free floating electrons once applied voltage is switch-off during pulsing operations. The liberated and electrically stabilized atom having a net electrical charge of "zero" exit the water bath for hydrogen gas utilization.

Dissociation of the water molecule by way of voltage stimulation is hereinafter called "The Electrical Polarization Process".

Subjecting or exposing the water molecule to even higher voltage levels causes the liberated atoms to go into an "state" of gas ionization. Each liberated atom taking-on its own "net" electrical charge. The ionized atoms along with free floating negative charge electrons are, now, deflected (pulsing electrical voltage fields of opposite polarity) through the Electrical Polarization Process...imparting or superimposing a second physical-force (particle impact) unto the electrically charged water bath. Oscillation (back and forth movement) of an electrically charged particles by way of Voltage deflection is hereinafter called "Resonant Action", as illustrated in Figure 12.

Attenuating and adjusting the "pulse-voltage-amplitude" with respect to the "pulse voltage frequency", now, produces hydrogen gas on demand while restricting amp flow from the power supply input.

LASER INTERACTION

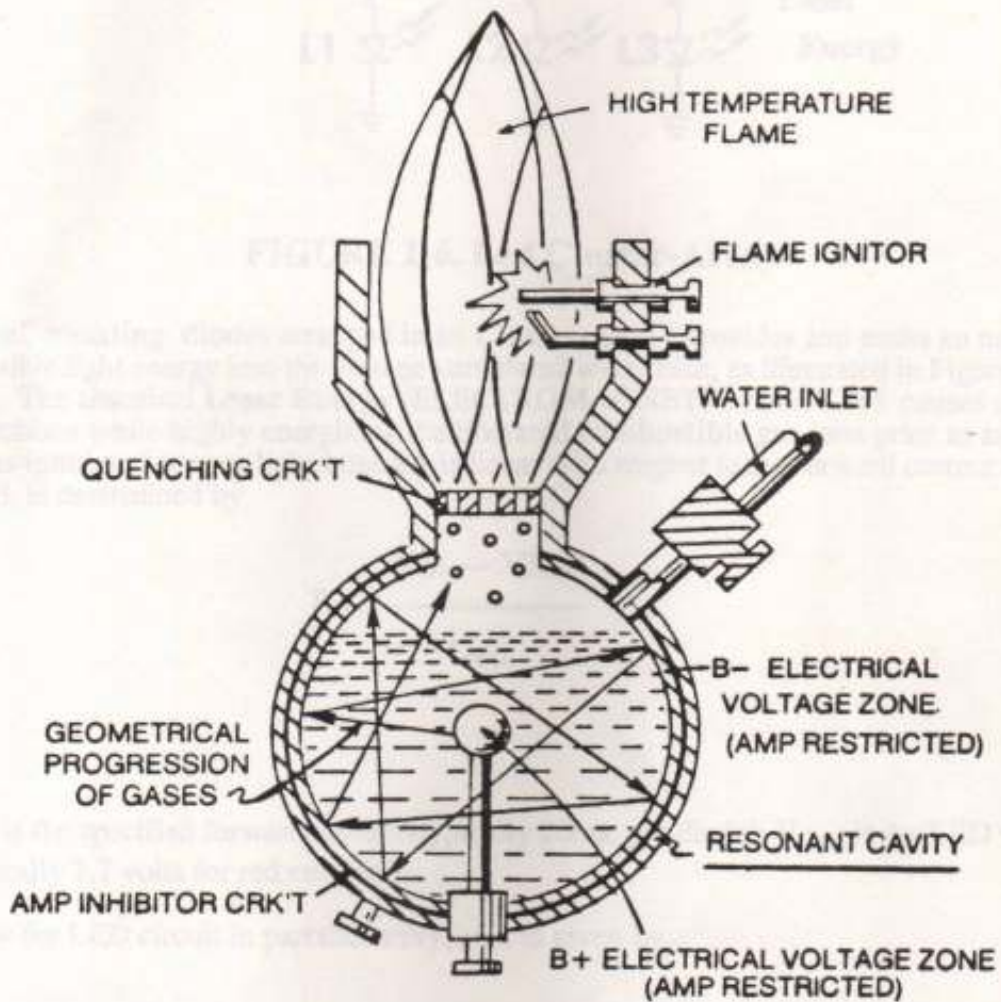

**FIG. 12: ELECTRICAL VOLTAGE ZONES (B-/B+) FORMING A RESONANT-CAVITY**

Copyright © 1982 by Stanley A. Meyer



## LASER INTERACTION

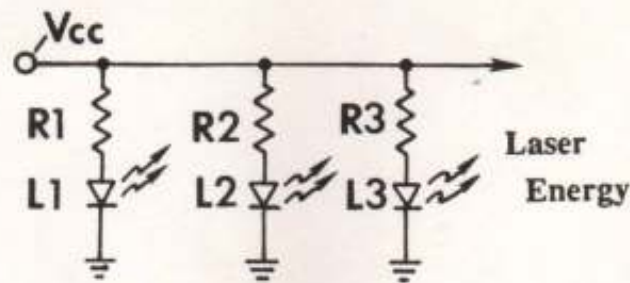

FIGURE 1-6. Led Cluster-Array

Light-emitting diodes arranged in an Cluster-Array provides and emits an narrow band of visible light energy into the voltage stimulated water bath, as illustrated in Figure 19 as to Figure 18. The absorbed Laser Energy (ELECTROMAGNETIC ENERGY) causes many atoms to lose electrons while highly energizing the liberated combustible gas ions prior to and during thermal gas-ignition. Laser or light intensity is linear with respect to the forward current through the LEDS, and, is determined by

$$R_s = \frac{V_{in} - V_{led}}{I_{led}}$$

Where

$I_{led}$  is the specified forward current (typically 20ma. per diode);  $V_{led}$  is the LED voltage drop (typically 1.7 volts for red emitters).

Ohm's Law for LED circuit in parrallel array, and, is given by

$$P_{watts} = V_{cc} I_t$$

Where

$I_t$  is the forward current through LED cluster-Array;  $V_{cc}$  is volts applied (typically 5 volts).

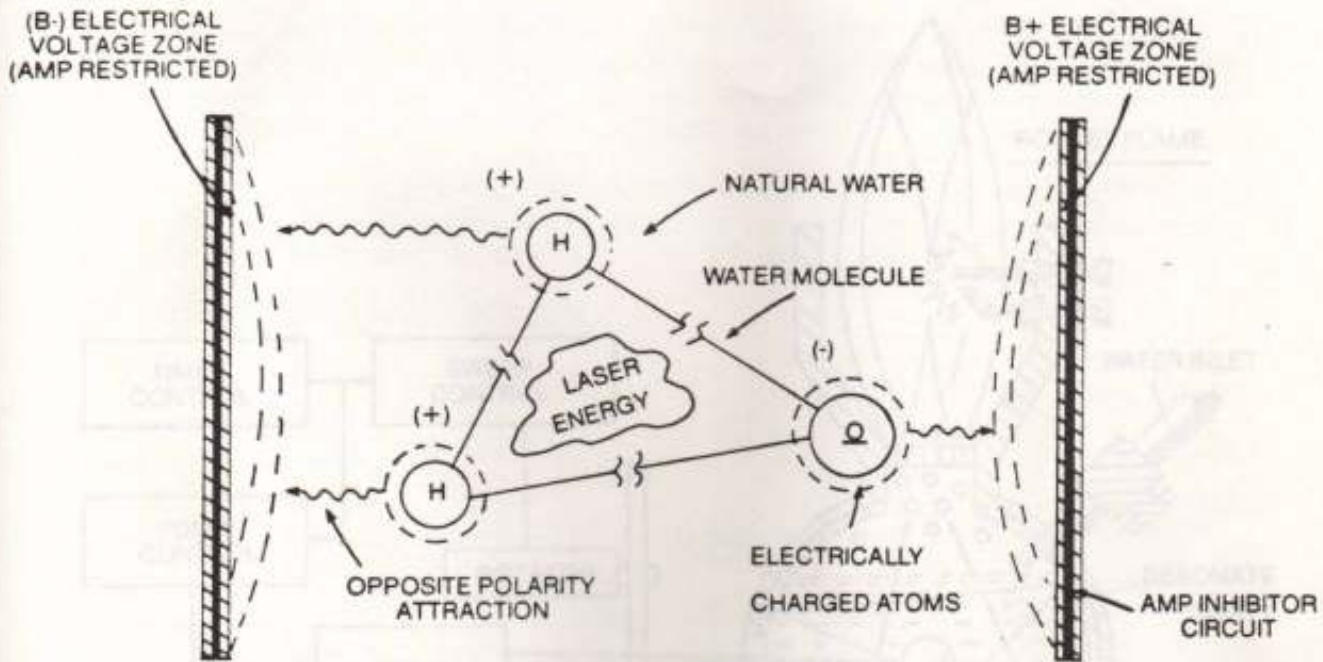

**FIG. 18: PHOTON ENERGY AIDS RESONANT-ACTION**

Copyright © 1983 by Stanley A. Meyer

**FIG. 19: LASER INJECTED RESONANT-CAVITY**

Copyright © 1983 by Stanley A. Meyer

Laser light intensity is variable as to duty cycle with pulse frequency from 1 Hz to 65 Hz, minimum, and is given by:

$$L = \frac{0.0012 \times T_1}{T_1 + T_2}$$

$T_1$  is light intensity in watts;  $T_2$  is current in amperes;  $T_1$  is number of times and  $0.0012 = RMS$  value of load current during no-period.

Injecting Laser Energy into the Electrical Polarization Process and controlling the intensity of the light energy through the Compton effect gas to reach an ionized state (ionization) by passing the combustible gas through which, in turn, excites the gas while raising the gas temperature beyond "normal" gas heating levels.

Injecting Chemically Neutral and Electrically Neutral gas into the rocket engine from water can be done by using the Compton effect gas to reach an ionized state (ionization) by passing the combustible gas through which, in turn, excites the gas while raising the gas temperature beyond "normal" gas heating levels.

ELECTRON EXTRACTION PROCESS

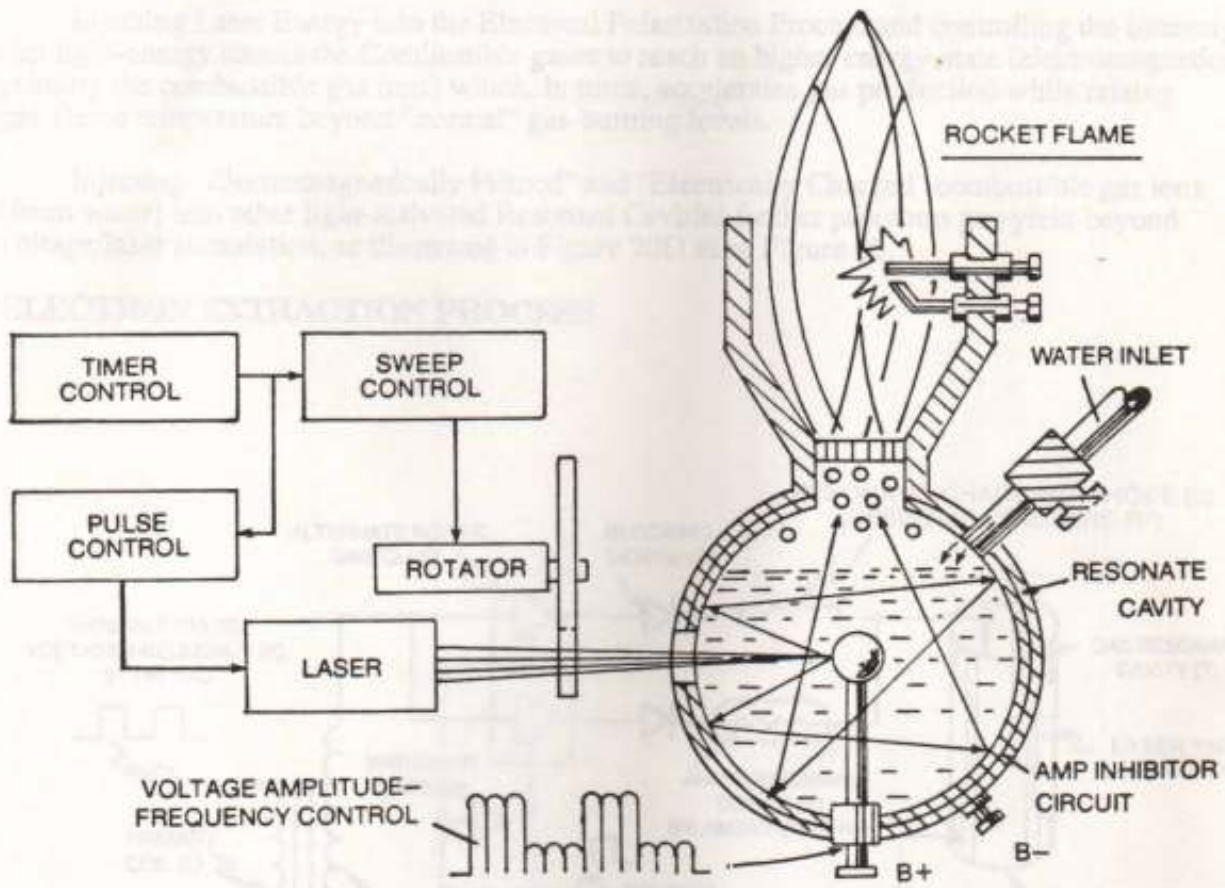

FIG. 19: LASER INJECTED RESONANT-CAVITY

Copyright © 1983 by Stanley A. Meyer

Whereby

Laser or light intensity is variable as to duty cycle on/off pulse-frequency from 1h<sub>z</sub> to 65 h<sub>z</sub> and above, and, is given by

$$L_e = \sqrt{\frac{(ION)^2 \times T_1}{T_1 + T_2}}$$

L<sub>e</sub> is light intensity in watts; T<sub>1</sub> is current on-time; T<sub>2</sub> is current off-time; and (ION) = RMS value of load current during on-period.

Injecting Laser Energy into the Electrical Polarization Process and controlling the intensity of that light-energy causes the Combustible gases to reach an higher energy-state (electromagnetically priming the combustible gas ions) which, in turns, accelerates gas production while raising gas-flame temperature beyond "normal" gas-burning levels.

Injecting "Electromagnetically Primed" and "Electrically Charged" combustible gas ions (from water) into other light-activated Resonant Cavities further promotes gas-yield beyond voltage/laser stimulation, as illustrated in Figure 20D as to Figure 20.

### ELECTRON EXTRACTION PROCESS

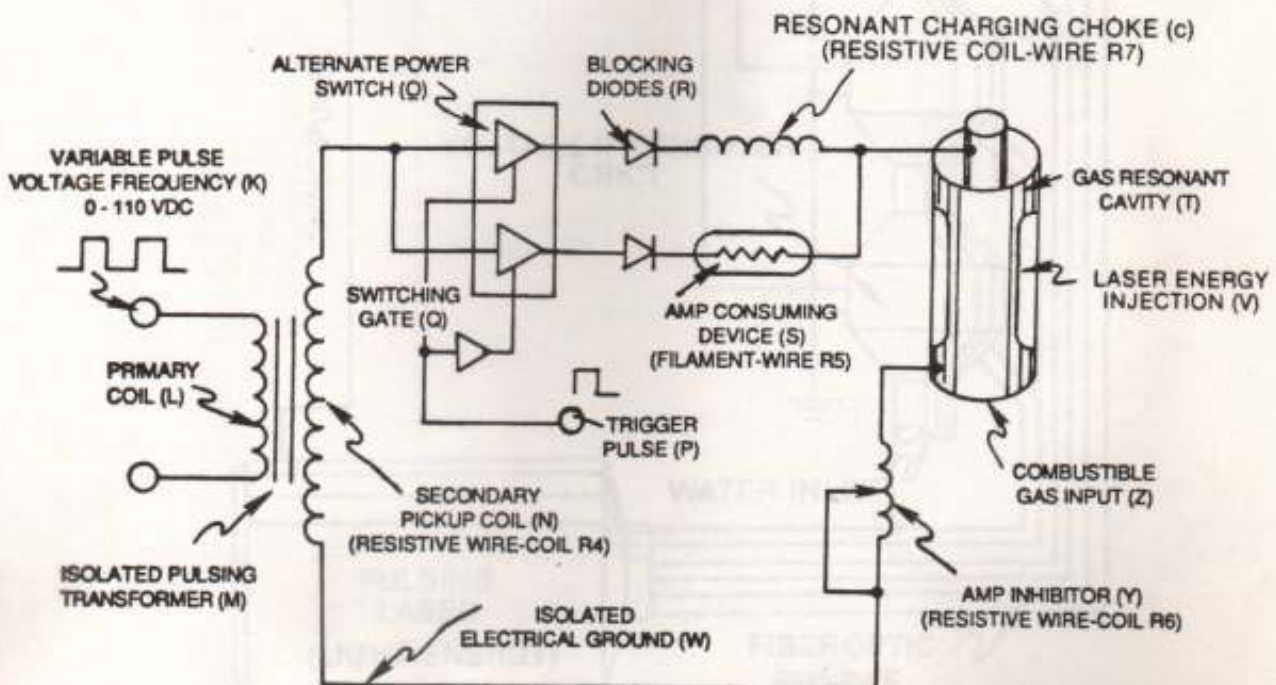

Copyright © 1982 By Stanley A. Meyer  
**FIG. 1-7. ELECTRON EXTRACTION CIRCUIT (BB)**

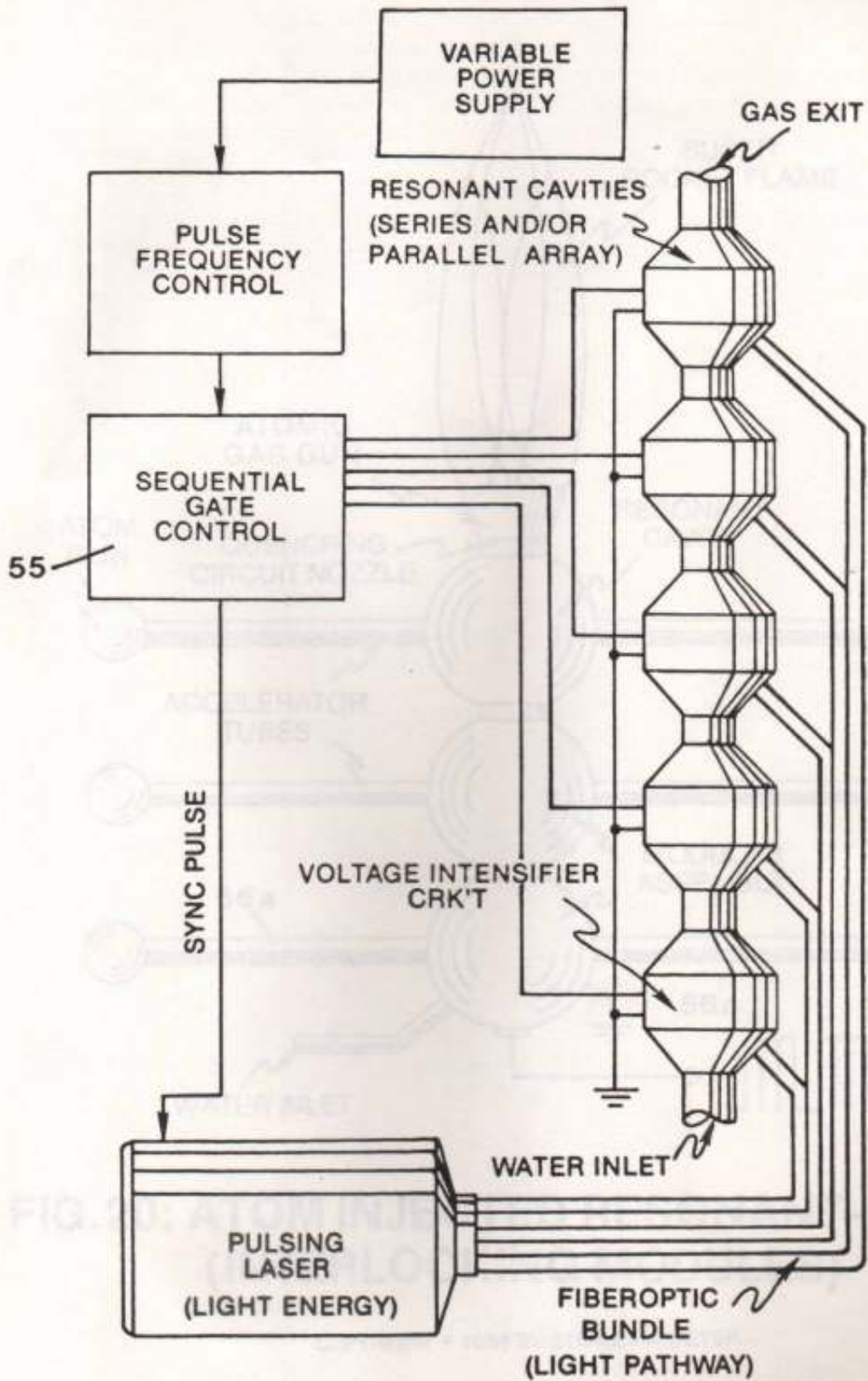

**FIG. 20D: POWER LOAD DISTRIBUTION**

COPYRIGHT © 1982 BY STANLEY A. MEYER

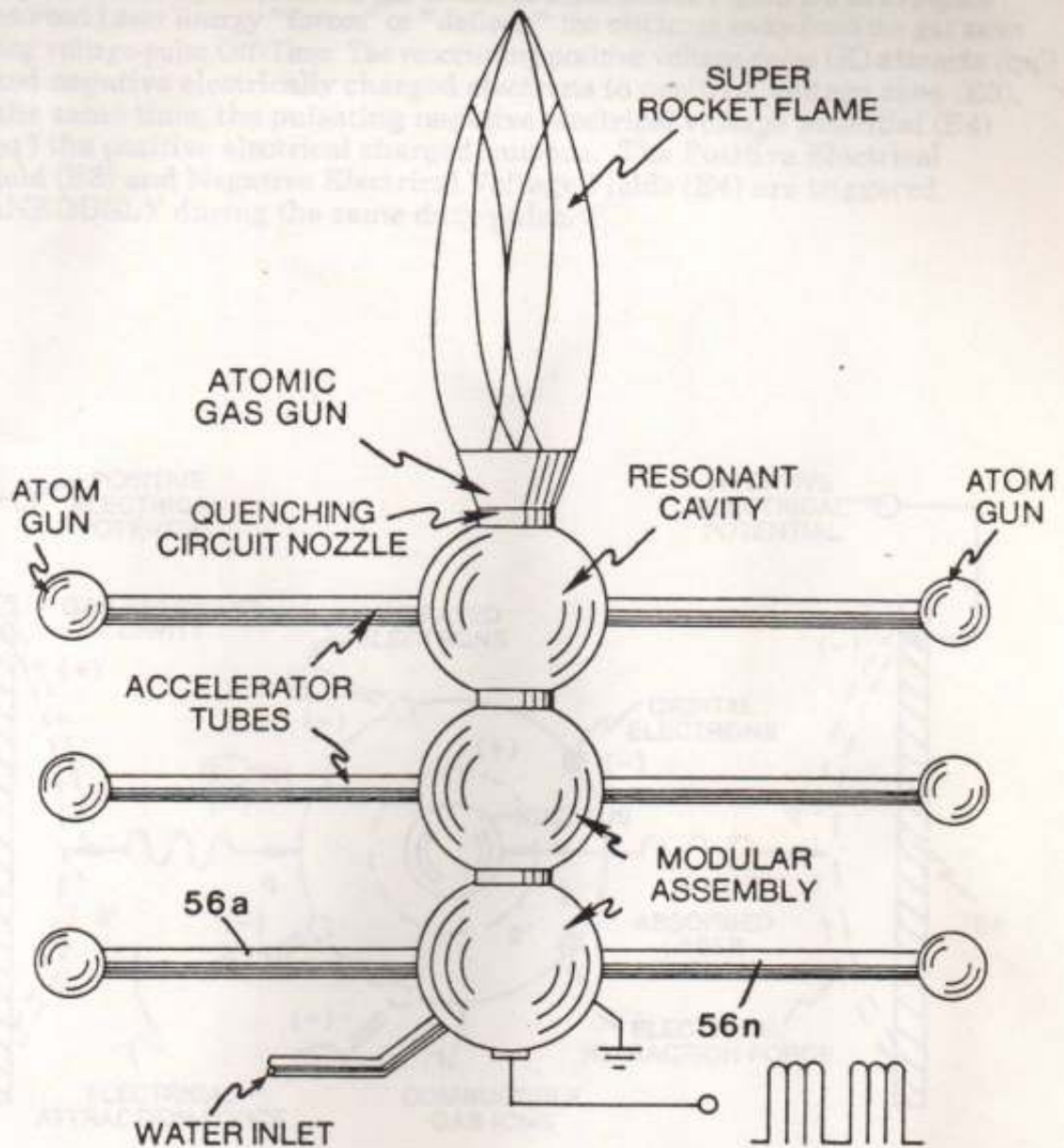

**FIG.20: ATOM INJECTED RESONANT-CAVITY (INTERLOCKING MODULES)**

COPYRIGHT © 1986 BY STANLEY A. MEYER

Exposing the displaced and moving combustible gas atoms (exiting water bath and passing through Gas Resonant Cavity (T), Figure 20JX as to Figure 20H) to another or separate pulsating laser energy-source (V) at higher voltage levels (E3/E4) causes more electrons to be "pulled away" or "dislodged" from the gas atoms, as illustrated in Figure 1-8 as to Figure 20F. The absorbed Laser Energy "forces" or "deflects" the electrons away from the gas atom nucleus during voltage-pulse Off-Time. The reoccurring positive voltage-pulse (K) attracts (qq') the liberated negative electrically charged electrons to positive voltage zone (E3). While, at the same time, the pulsating negative electrical voltage potential (E4) attracts (qq') the positive electrical charged nucleus. The Positive Electrical Voltage Field (E3) and Negative Electrical Voltage Fields (E4) are triggered SIMULTANEOUSLY during the same duty-pulse.

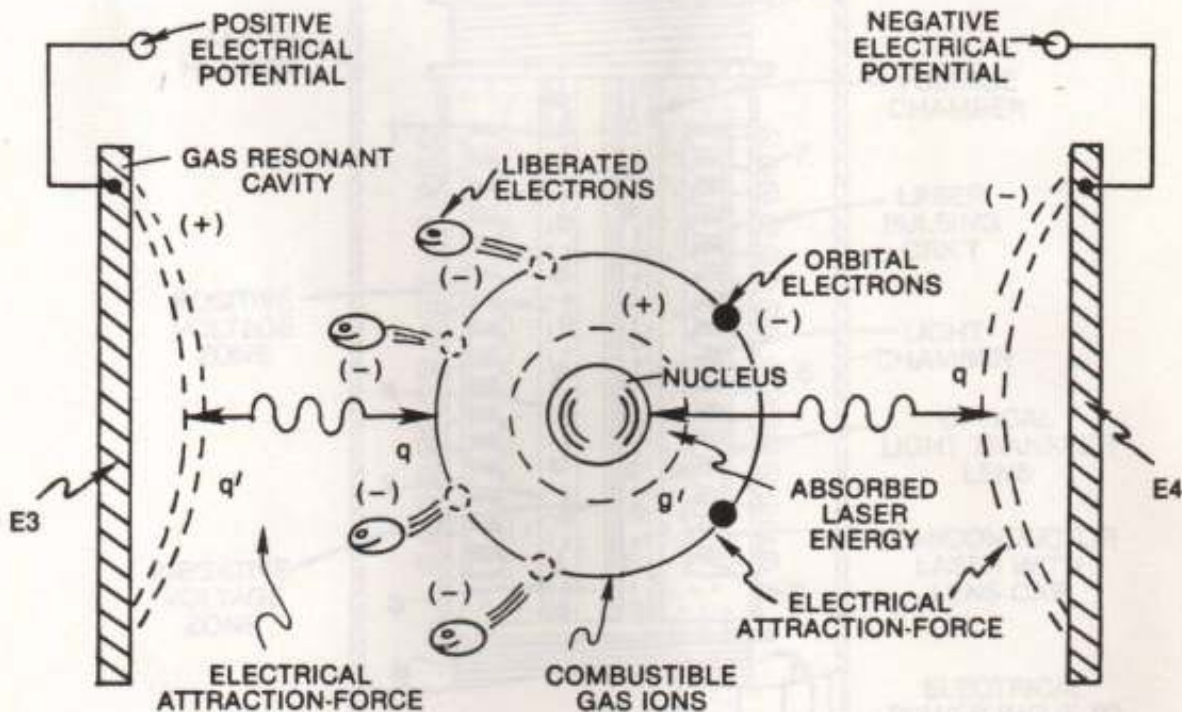

Copyright © 1982 By Stanley A. Meyer

Fig. 1-8. DESTABILIZING COMBUSTIBLE GAS IONS

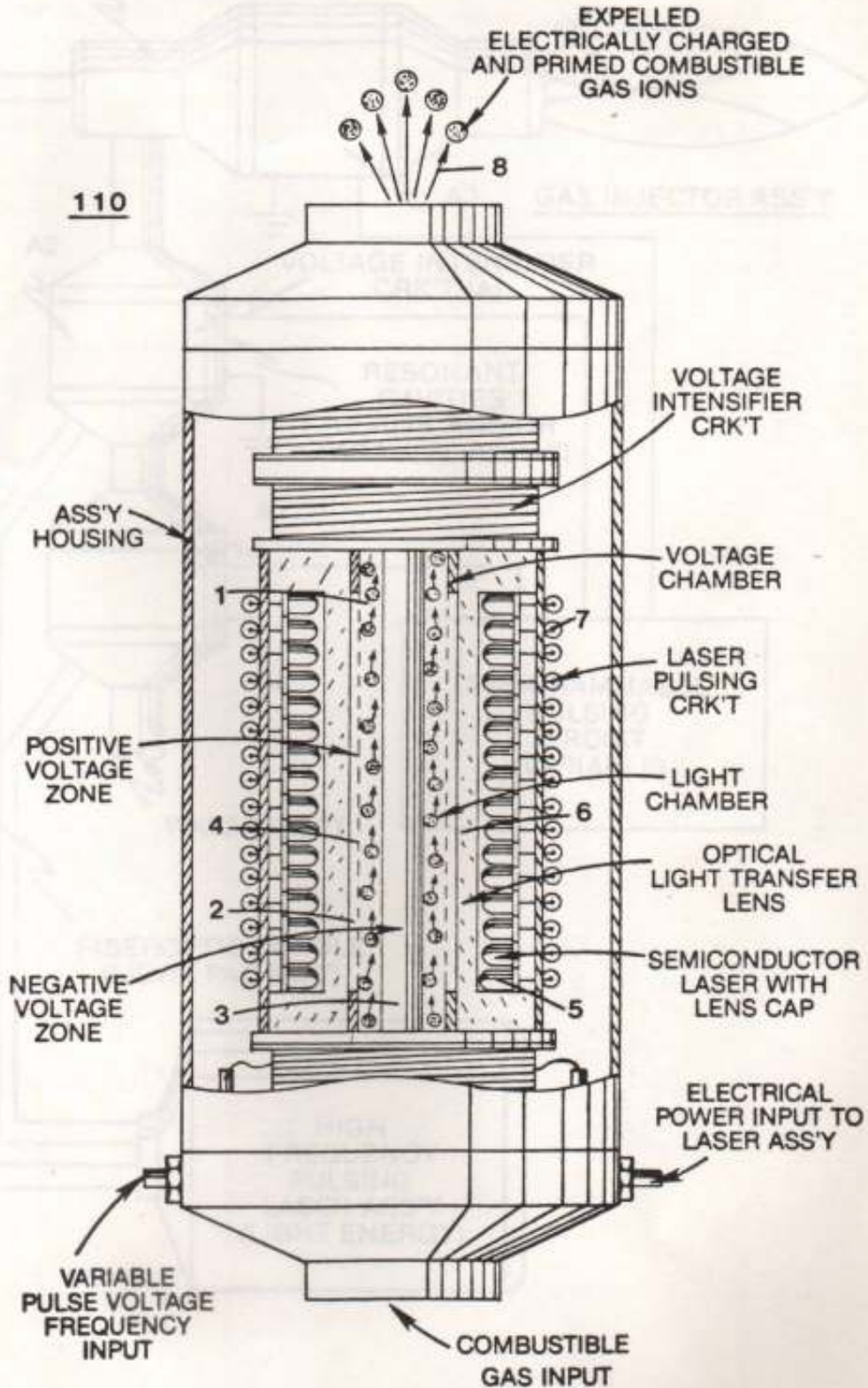

**FIG. 20JX: GAS RESONANT CAVITY**

COPYRIGHT © 1983 BY STANLEY A. MEYER



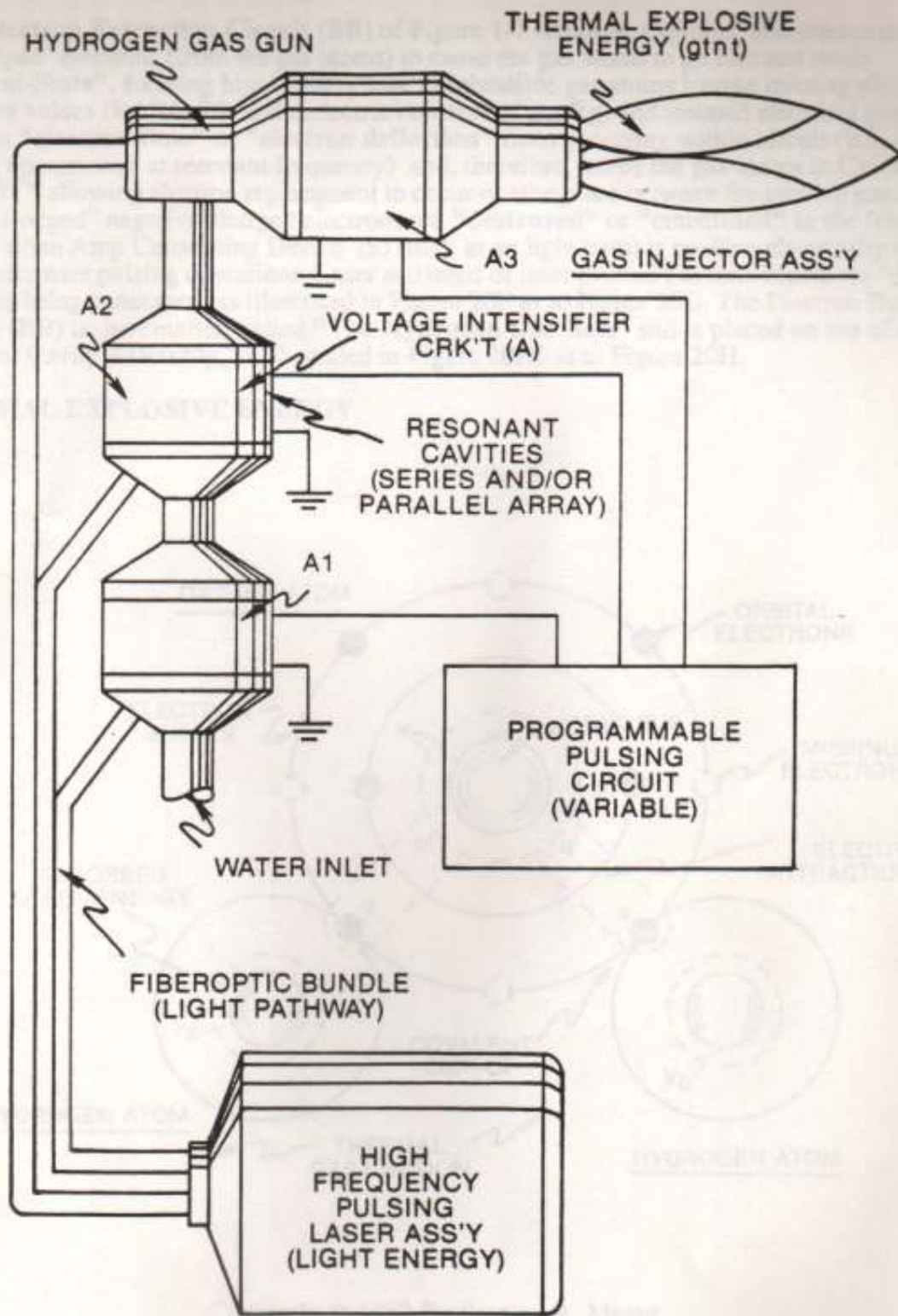
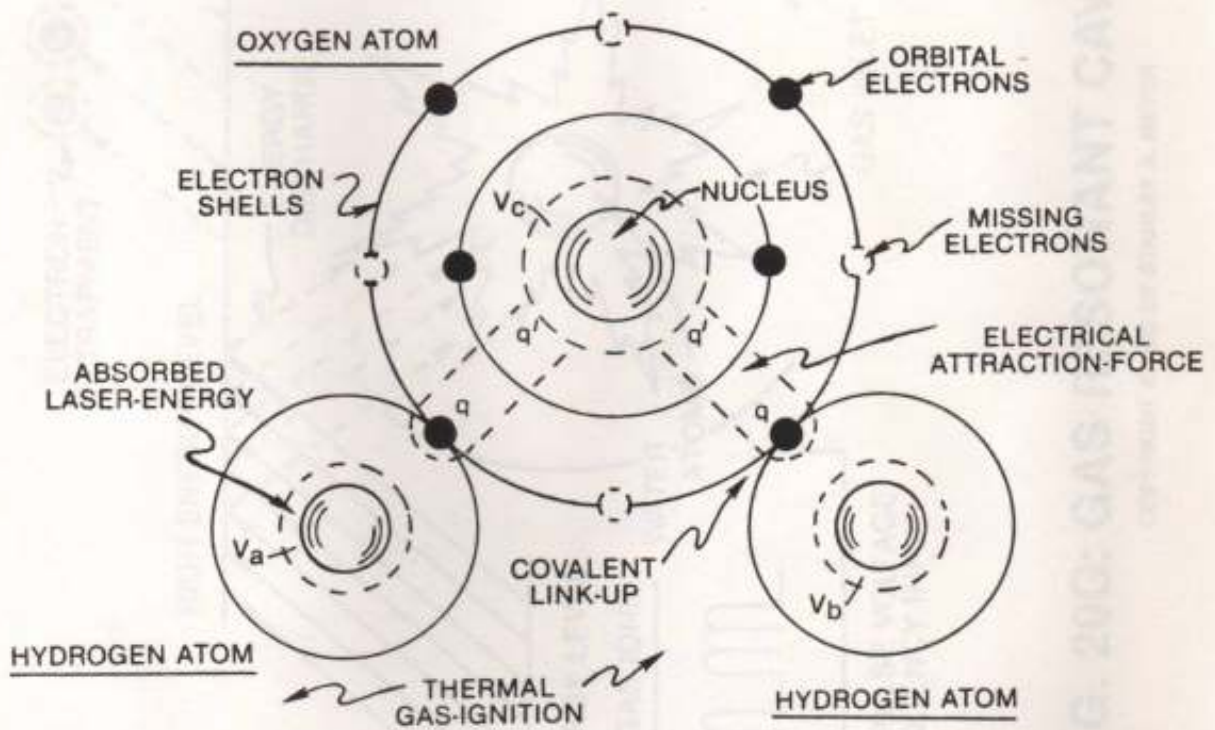

**FIG. 20H: GAS INJECTOR FUEL CELL**

COPYRIGHT © 1983 BY STANLEY A. MEYER

Electron Extraction Circuit (BB) of Figure 1-7 removes, captures, and consumes the "dislodged" electrons (from the gas atoms) to cause the gas atoms to go into and reach "Critical-State", forming highly energized combustible gas atoms having missing electrons. Resistive values ( $R_4, R_6, R_7$ , and dielectric constant of gas  $R_g$ ) and isolated electrical ground (W) prevents "electron-flow" or "electron deflection" from occurring within circuit (BB) during pulsing operations ( at resonant frequency) and, therefore, keeps the gas atoms in Critical-State by "NOT" allowing electron replacement to occur or take place between the moving gas atoms. The "dislodged" negative charged electrons are "destroyed" or "consumed" in the form of "heat" when Amp Consuming Device (S) (such as an light bulb) is positive electrically energized during alternate pulsing operations. Laser activated or laser primed gas ions repels the "dislodge" electrons being consumed, as illustrated in Figure 20F as to Figure 20G. The Electron Extraction Process (BB) is, hereinafter, called "The Hydrogen Gas Gun" and is placed on top of an Resonant Cavity Assembly, as illustrated in Figure 20JX as to Figure 20H.

**THERMAL EXPLOSIVE ENERGY**



Copyright © 1982 By Stanley A. Meyer

Fig.1-9. HYDROGEN FRACTURING PROCESS

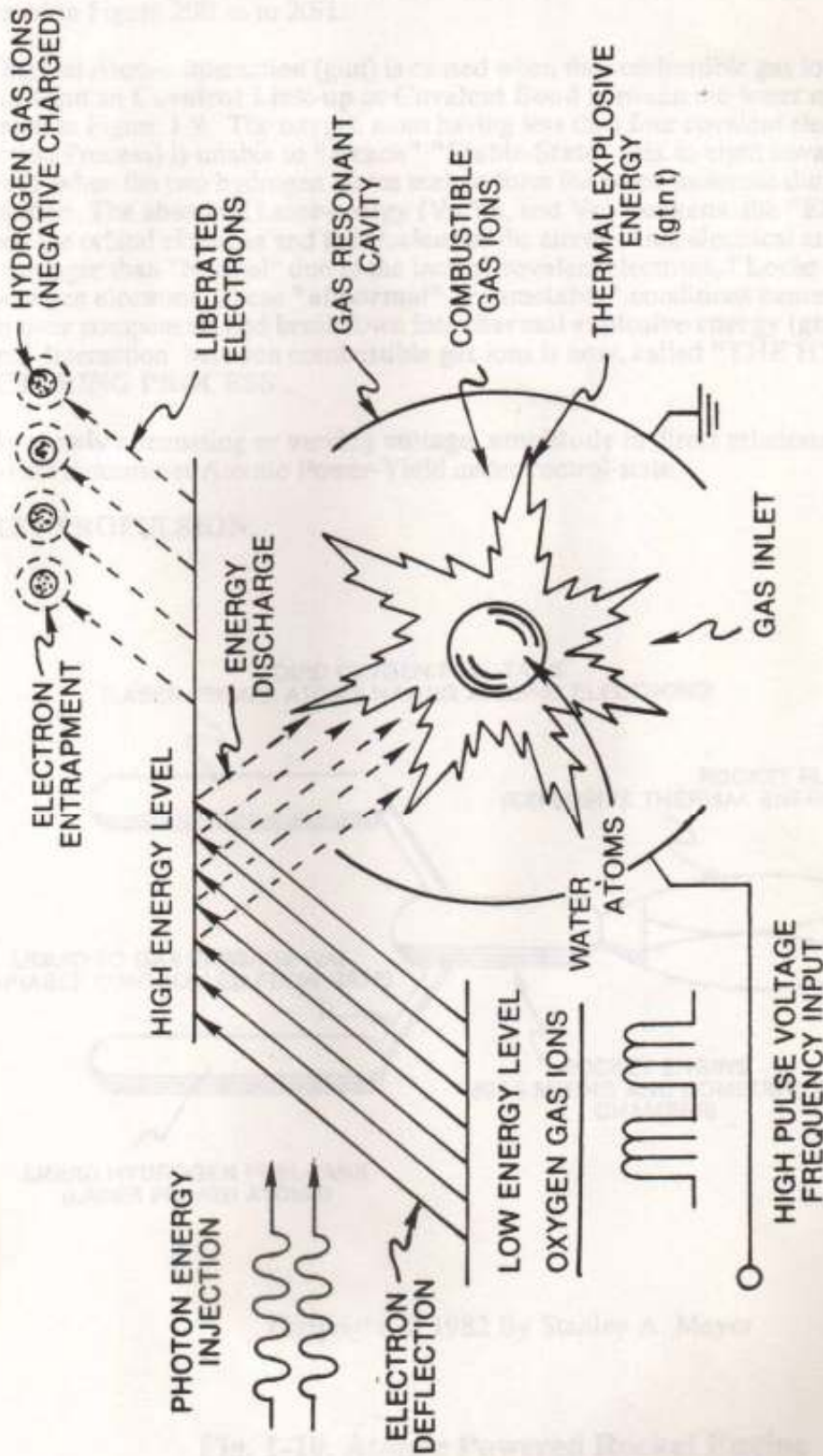

FIG. 20G: GAS RESONANT CAVITY

COPYRIGHT © 1983 BY STANLEY A. MEYER

Exposing the expelling "Laser-Primed" and "Electrically Charged" combustible gas ions (exiting from Gas Resonant Cavity) to an thermal-spark or heat-zone causes thermal gas-ignition, releasing **thermal explosive energy (gtnt)** beyond the Gas-Flame Stage, as illustrated in Figure 20E as to 20H.

Thermal Atomic interaction (gtnt) is caused when the combustible gas ions (from water) fail to unite or form an **Covalent Link-up** or **Covalent Bond** between the water molecule atoms, as illustrated in Figure 1-9. The oxygen atom having less than four covalent electrons (Electron Extraction Process) is unable to "Reach" "Stable-State" (six to eight covalent electrons required) when the two hydrogen atoms seek to form the water molecule during thermal gas-ignition. The absorbed Laser-energy ( $V_a, V_b$ , and  $V_c$ ) weakens the "Electrical Bond" between the orbital electrons and the Nucleus of the atoms. And, electrical attraction-force ( $qq'$ ), being stronger than "Normal" due to the lack of covalent electrons, "Locks Onto" and "Keeps" the hydrogen electrons. These "abnormal" or "unstable" conditions causes the combustible gas ions to over compensate and breakdown into **thermal explosive energy (gtnt)**. This Atomic Thermal-Interaction between combustible gas ions is now, called "THE HYDROGEN FRACTURING PROCESS'.

By simply attenuating or varying **voltage amplitude** in direct relationship to **voltage pulse-rate** determines Atomic Power-Yield under control-state.

## ROCKET PROPULSION

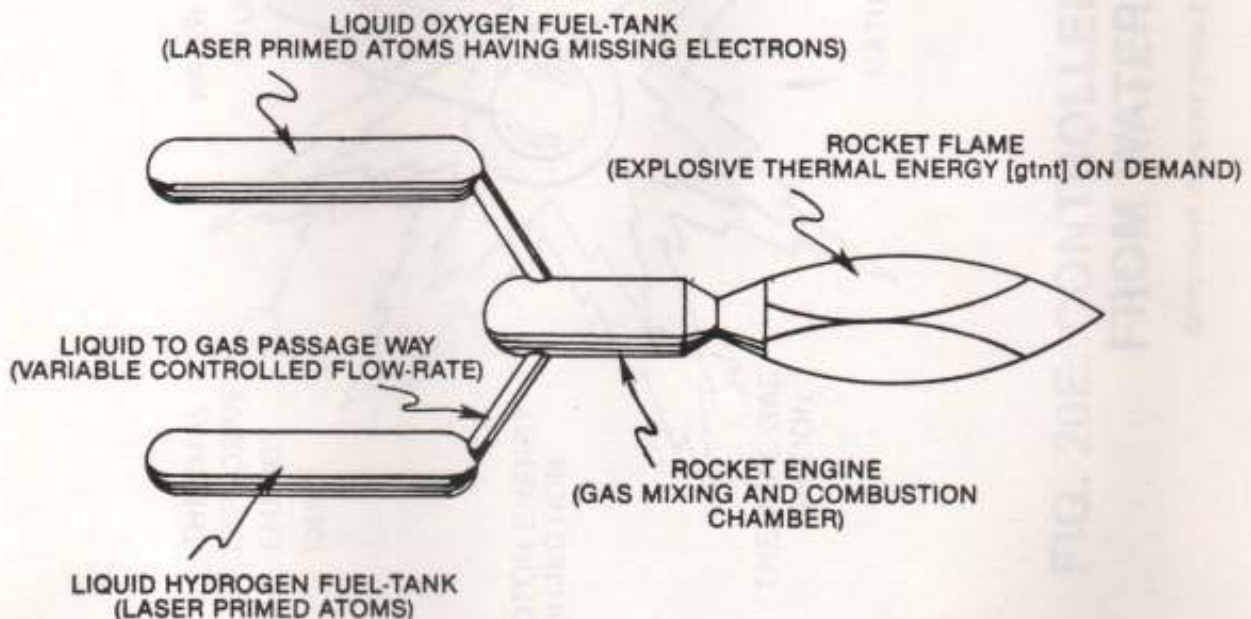

Copyright © 1982 By Stanley A. Meyer

**Fig. 1-10. Atomic Powered Rocket Engine**

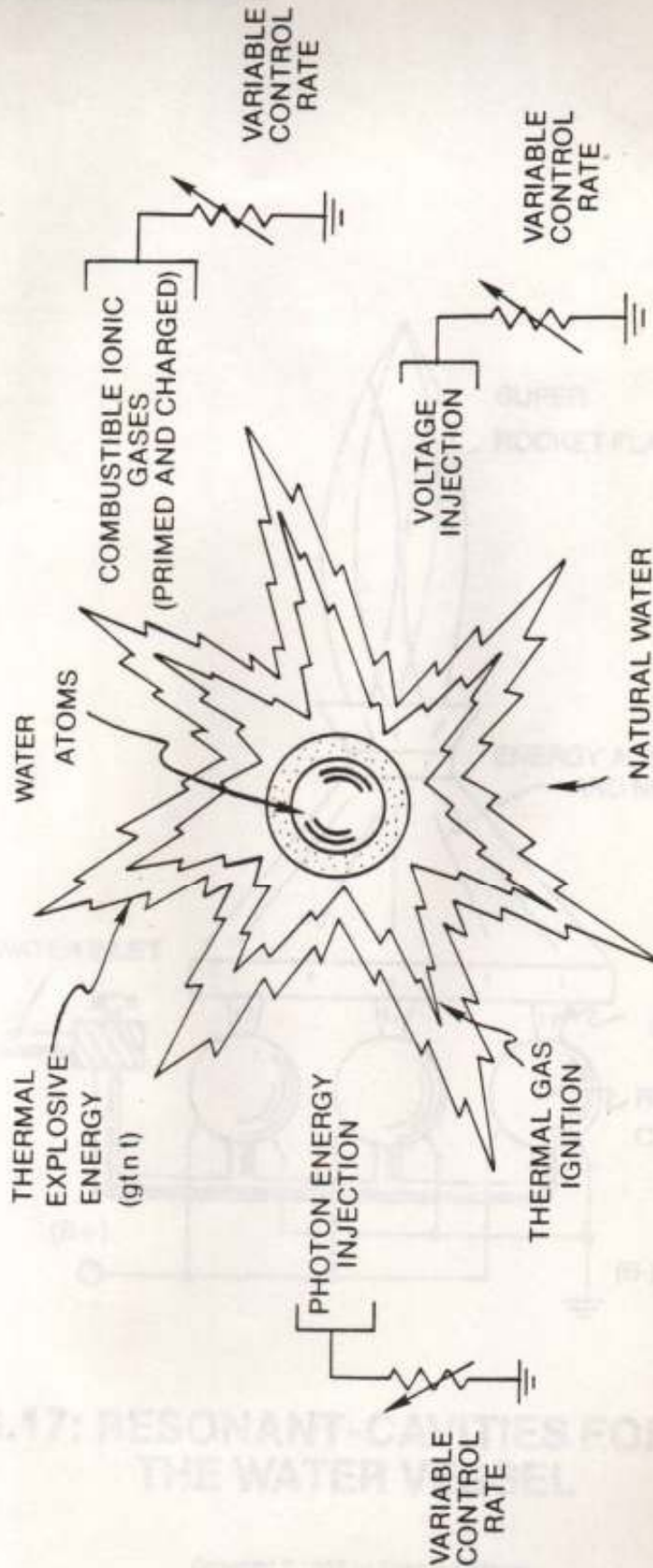

**FIG. 20E: CONTROLLED ENERGY-YIELD FROM WATER ATOMS**

COPYRIGHT © 1983 BY STANLEY A. MEYER

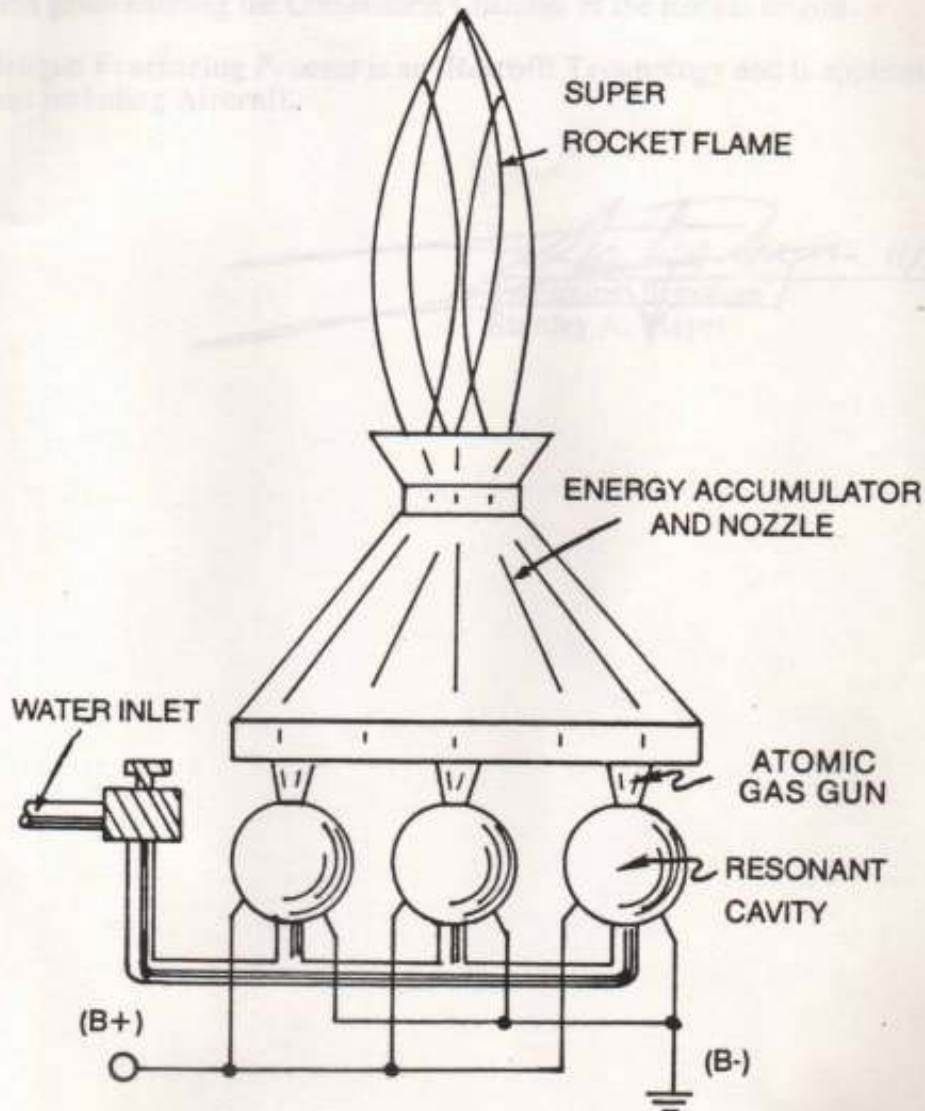

**FIG.17: RESONANT-CAVITIES FORMING THE WATER VESSEL**

Copyright © 1982 by Stanley A. Meyer

Add-on Resonant Cavities (placed beneath the Hydrogen Gas Gun Assembly) arranged in parallel to verticle **Cluster-Array** increases the Atomic Energy-yield of The Hydrogen Fracturing Process undergoing thermal gas-ignition, as illustrated in Figure 17 as to Figure 20. This **Cluster-Assembly** or **Cluster-form** is, hereinafter, called "**The Water Powered Rocket Engine**"

Prolong Rocket-Flight carrying heavier pay-loads is achieved by **Liquifing** the "**specially treated**" Combustible Gas Ions (laser-primed oxygen gas-atoms having missing electrons and laser-primed hydrogen gas-atoms) under pressure in separate Fuel-Tanks affixed to an "**Rocket Engine**", as illustrated in Figure 1-10. **Rocket-Thrust** is, now, controlled by the flow-rate of the Combustible ion gases entering the Combustion Chamber of the Rocket Engine.

The **Hydrogen Fracturing Process** is an **Retrofit Technology** and is applicable to all Energy-systems including **Aircraft**.

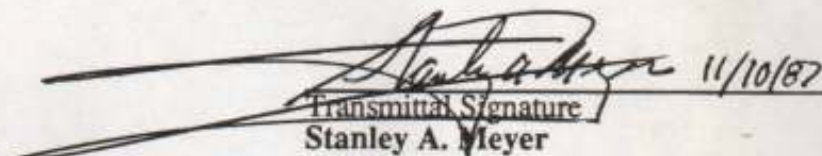
 11/10/87  
Transmittal Signature  
Stanley A. Meyer